



Contents lists available at ScienceDirect

Journal of Computational and Applied Mathematics

journal homepage: www.elsevier.com/locate/cam

A novel linearized power flow approach for transmission and distribution networks

B. Sereeter*, A.S. Markensteijn, M.E. Kootte, C. Vuik

Delft Institute of Applied Mathematics, Delft University of Technology, Van Mourik Broekmanweg 6, 2628XE, Delft, The Netherlands



ARTICLE INFO

Article history:

Received 17 July 2020

Keywords:

Linear power flow
 Nonlinear power flow
 Constant impedance model
 PV-buses
 Distribution networks

ABSTRACT

Power flow computations are important for operation and planning of the electricity grid, but are computationally expensive because of nonlinearities and the size of the system of equations. Linearized methods reduce computational time but often have the disadvantage that they are not applicable to general grids. In this paper we propose a novel linearized power flow (LPF) technique that is able to handle PQ- and PV-buses, and works on both transmission and distribution networks. This technique is based on previous work on handling PQ-buses by connecting them to artificial-additional ground buses. We extend this idea to PV-buses. Test-cases show that the novel LPF method leads to similar accuracy as nonlinear power flow (NPF) methods while significantly reducing computation time. Therefore, the general LPF methods is a good alternative to NPF methods.

© 2021 The Author(s). Published by Elsevier B.V. This is an open access article under the CC BY license (<http://creativecommons.org/licenses/by/4.0/>).

1. Introduction

Transmission and distribution system operators use power flow simulations to ensure stability and safe operation of the electricity grid. These simulations are computationally expensive because the power flow problem is formulated as a nonlinear system of equations, and they run on large problem sizes, i.e. grids with millions of lines and other elements. Iterative methods such as the Gauss–Seidel, Newton power flow and Fast Decoupled Load Flow are widely used to solve the nonlinear power flow (NPF) problem for transmission networks [1–4].

Another way to solve the power flow problem is by linearization. Numerous researchers developed methods to obtain linear power flow equations using several approximations and assumptions. These computations are generally faster than NPF computations, but might be less accurate due to simplifications of the nonlinear equations. Despite the loss of accuracy, these linearized approaches can be more suitable than NPF computations when they are used to solve very large networks with millions of cables in real-time simulations. DC load flow [5] is a well-known linear method where linear relations are determined between the active power injections P and the voltage angles δ , and between the reactive power injections Q and the deviations of the unknown voltage magnitudes $\Delta|V|$. Another linear power flow formulation is introduced in [6] and is based on a voltage-dependent load model and some numerical approximations on the imaginary part of the nodal voltages. The linearized method of [7] is based on Taylor's series expansion and works on low voltage DC power grids. It was extended to run on more advanced DC grids in [8], and to distribution networks including distributed generation in [9]. The authors of [10] propose a single-phase linear method that includes the handling of generator buses. Three-phase linear power flow methods also exist, such as proposed in [11,12] and [13]. The first one can handle load buses only, the latter uses the ZIP¹-model to model load buses and generator buses.

* Corresponding author.

E-mail address: baljinnyamss@gmail.com (B. Sereeter).

¹ Combination of constant impedance Z, current I, and power P load models.

In this paper, we describe a modification of a linearized method that is based on the Z_{bus} and Y_{bus} method [3]. The Z_{bus} methods solve the linear equation between voltages and currents directly using the impedance-to-ground relation for load buses. The Z_{bus} methods have good convergence characteristics compared to other methods, but the non-sparse Z -matrix required more storage, and with the computational power at that time, around 1970, it sacrificed speed. The rise of other fast and robust methods, among which Newton–Raphson, put the developments of this method on hold.

Recently, the idea of using the impedance-to-ground loads was reintroduced in [14], using a Y_{bus} method. The results of this method are promising because the computational time is significantly lower than current non-linear methods. However, this method only considers load buses.

In this paper, we extend this method to also handle generator buses. Since the extended method can handle both PQ- and PV-buses, this linear method can be used for both transmission and distribution networks. Furthermore, we introduce an iterative approach to solve the resulting linear power flow problem.

In the rest of this paper we describe the nonlinear power flow problem (Section 2) and its modification to our linear power flow problem for both load and generator buses (Section 3). To solve the linearized problem, we propose two approaches, a direct and an iterative approach (Section 4). We apply the linear power flow method to several transmission and distribution test-cases, and compare the results with NPF computations on the same test-cases (Section 5). Finally, we give some concluding remarks (Section 6).

2. Nonlinear power flow problem

For an AC steady-state approximation of a power grid, the power flow problem is formulated as follows (e.g [5]). First, the power grid is represented as a network. Then in every bus i , Kirchhoff's Current Law (KCL) holds:

$$I_i = \sum_j I_{ij}. \tag{1}$$

Here, I_i is the total injected current, and I_{ij} is the current through an edge between bus i and bus j , and is given by an extension of Ohm's law to the AC case:

$$I_{ij} = Y_{ij}(V_i - V_j), \tag{2}$$

with Y_{ij} the admittance, and $V_i = |V_i|e^{j\delta_i}$ the bus voltage. In every bus, the total injected complex power is determined by

$$S_i = P_i + jQ_i = V_i I_i^*, \tag{3}$$

where S_i , P_i , and Q_i are the injected complex, active, and reactive power, and where $[\cdot]^*$ denotes the complex conjugate. Combining KCL (1) with the extensions of Ohm's law (2), and substituting it in the complex power equation (3), gives the nonlinear power flow equation for every bus i :

$$S_i = V_i (YV)_i^*, \tag{4}$$

with Y the admittance matrix of the power grid, and V to vector of bus voltages.

3. Linear power flow problem

The linear approach is based on the former Z_{bus} method [3], and adjusted to a Y_{bus} method [14]. Instead of solving the nonlinear power flow Eqs. (4), we substitute Ohm's law (2) into KCL (1) to obtain the following system of equations:

$$I = YV, \tag{5}$$

with I the vector of injected currents. It is impossible to compute the voltage V directly from (5), because current I is generally unknown. Therefore, we use an impedance-to-ground relation similar to one used in [14] and [15]. Moreover, we extend this approach to include generator buses, also called PV-buses. First, we connect all nonzero load buses $n = 1, \dots, N$ and all generator buses $k = 1, \dots, K$ in the network to artificial ground buses $g = 1, \dots, G$, with $G = N + K$. These additional ground buses are then included in the network, as illustrated in Fig. 1. The injected power of nonzero load n and generator k is shifted to the artificial-additional ground bus, such that the buses \tilde{n} and \tilde{k} have zero injected power and current. The connection between the artificial-additional ground bus and the new bus \tilde{n} or \tilde{k} is modeled as a short transmission line. We use one index i to denote either the nonzero load bus n or the generator bus k , and thus \tilde{i} for either \tilde{n} or \tilde{k} . This results in the following expression of the new transmission line:

$$\begin{aligned} P_{ig} &= G_{ig}|V_i|^2 - |V_i| \| V_g \| (G_{ig} \cos \delta_{ig} + B_{ig} \sin \delta_{ig}) \\ Q_{ig} &= -B_{ig}|V_i|^2 - |V_i| \| V_g \| (G_{ig} \sin \delta_{ig} - B_{ig} \cos \delta_{ig}) \end{aligned} \tag{6}$$

Here, G_{ig} and B_{ig} are the conductance and susceptance of the new line and $\delta_{ig} := \delta_i - \delta_g$ is the voltage angle difference.

We require that bus \tilde{i} acts the same as bus i , as seen from the rest of the network. That is, we assume that:

$$\begin{aligned} |V_i| &= |V_{\tilde{i}}|, & \delta_i &= \delta_{\tilde{i}}, \\ P_{ig} &= P_i, & Q_{ig} &= Q_i. \end{aligned} \tag{7}$$

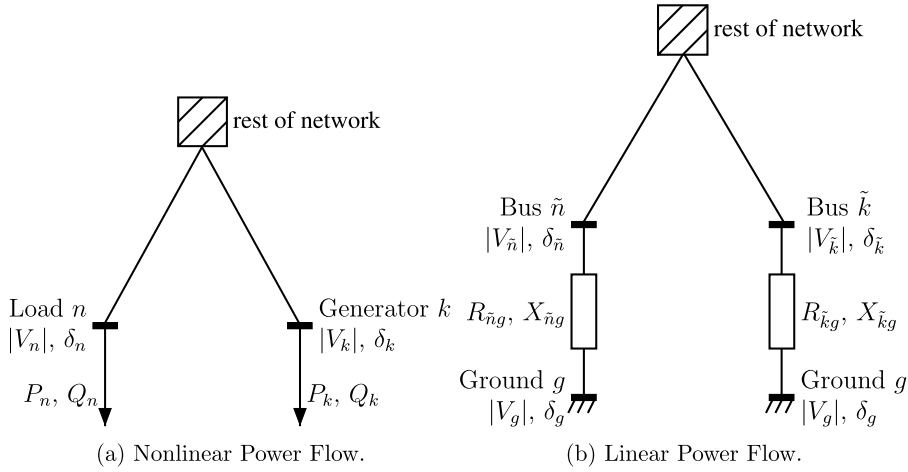

Fig. 1. Network representation of a load bus n and a generator bus k for standard NPF (a) and for LPF (b).

Furthermore, we set the voltage magnitude of the artificial-additional ground bus to zero, that is $V_g = 0$. Substituting these assumptions in (6), the conductance and susceptance for the additional lines are given by:

$$\begin{aligned} G_{ig} &= \frac{P_i}{|V_i|^2}, \\ B_{ig} &= \frac{-Q_i}{|V_i|^2}. \end{aligned} \tag{8}$$

Resistance R_{ig} and reactance X_{ig} for the additional lines are computed by substituting (8) into $R + iX = \frac{1}{Y} = \frac{G}{|Y|^2} - \frac{B}{|Y|^2}i$:

$$\begin{aligned} R_{ig} &= \frac{|V_i|^2 P_i}{P_i^2 + Q_i^2}, \\ X_{ig} &= \frac{|V_i|^2 Q_i}{P_i^2 + Q_i^2}. \end{aligned} \tag{9}$$

For a nonzero load node n , the injected active P_n and reactive power Q_n are known, while for a generator node k , the voltage magnitude $|V_k|$ and injected active power P_k are specified. Denoting unknown quantities by $[\hat{\cdot}]$, the resistance $R_{\tilde{n}g}$ and reactance $X_{\tilde{n}g}$ of the additional branches for nonzero load buses n become:

$$\begin{aligned} R_{\tilde{n}g} &= \frac{|\hat{V}_n|^2 P_n}{P_n^2 + Q_n^2}, \\ X_{\tilde{n}g} &= \frac{|\hat{V}_n|^2 Q_n}{P_n^2 + Q_n^2}. \end{aligned} \tag{10}$$

We know that the voltage is specified for the swing bus in the original network, which is called the reference voltage V_{ref} . For both the generator buses and the swing bus, we set the voltage magnitude to nominal voltage levels:

$$|V_{ref}| = 1 \text{ p.u.}, \quad |V_k| = 1 \text{ p.u.} \tag{11}$$

In practice, the voltage magnitude of the generator buses can be different than 1 p.u., such as 1.06 p.u. or 1.045 p.u. Since it is still a known value, the performance of the power flow computation is not affected. The resistance R_{kg} and reactance X_{kg} of the additional branches for generator buses k are then given by:

$$\begin{aligned} R_{kg} &= \frac{P_k}{P_k^2 + \hat{Q}_k^2}, \\ X_{kg} &= \frac{\hat{Q}_k}{P_k^2 + \hat{Q}_k^2}. \end{aligned} \tag{12}$$

As a result of the artificial-additional ground buses and additional lines, the number of buses and branches in the network increases by $N + K$. Using the resistances and reactances (10) and (12), we can build the new admittance matrix

\bar{Y} including the additional branches. Thus, we obtain the following linear power flow equation:

$$\bar{I} = \bar{Y}\bar{V} \tag{13}$$

with

$$\bar{I} = \begin{bmatrix} I_g \\ I \end{bmatrix}, \bar{Y} = \begin{bmatrix} Y_{gg} & Y_{ig}^T \\ Y_{ig} & Y \end{bmatrix}, \bar{V} = \begin{bmatrix} V_g \\ V \end{bmatrix}. \tag{14}$$

Here I , V , and Y are the original current vector, voltage vector, and admittance matrix respectively, whereas I_g , V_g and Y_{gg} are the current vector, voltage vector, and admittance matrix with respect to the additional ground buses.

Note that (13) still cannot be solved directly because not all elements in vector \bar{I} or \bar{V} are known. Due to the explicit use of the impedance-to-ground connection of the load and generator nodes, and since the voltage at the swing bus is given, we can order (13) in such a way that the swing bus voltage V_{ref} and all ground bus voltages V_g are placed in V_1 , and all unknown voltages of the remaining buses are placed in V_2 as:

$$\begin{bmatrix} I_1 \\ I_2 \end{bmatrix} = \begin{bmatrix} Y_{11} & Y_{21}^T \\ Y_{21} & Y_{22} \end{bmatrix} \begin{bmatrix} V_1 \\ V_2 \end{bmatrix}. \tag{15}$$

Due to the shift of the injected power from the original load and generator nodes to the additional ground buses, KCL dictates that $\sum I_{ij} = 0$ for every bus \tilde{i} in V_2 . Therefore, $I_2 = 0$ and the power flow equations become:

$$\begin{bmatrix} I_1 \\ 0 \end{bmatrix} = \begin{bmatrix} Y_{11} & Y_{21}^T \\ Y_{21} & Y_{22} \end{bmatrix} \begin{bmatrix} V_1 \\ V_2 \end{bmatrix}. \tag{16}$$

The second row of (16) is a linear system of equations for the unknown V_2 , since V_1 is known. Then, the voltages V of the original network can be assembled as

$$V = \begin{bmatrix} V_{ref} \\ V_2 \end{bmatrix}. \tag{17}$$

4. Linear power flow solution method

The resistances $R_{\tilde{n}g}$ and reactances $X_{\tilde{n}g}$ of the artificial-additional branches connecting nonzero load buses to ground buses depend on the unknown voltage magnitudes $|\hat{V}_n|$ of the nonzero load buses. Similarly, resistances $R_{k\tilde{g}}$ and reactances $X_{k\tilde{g}}$ connecting generator buses to ground buses depend on the unknown reactive powers \hat{Q}_k of the generator buses. Hence, for every nonzero load node n , a value for $|\hat{V}_n|$ needs to be estimated, and for every generator node k , a value for \hat{Q}_k needs to be estimated. The first option is to use some fixed value for $|\hat{V}_n|$ and \hat{Q}_k for the LPF computation, which we call the direct approach. A second option is to determine $|\hat{V}_n|$ and \hat{Q}_k during the LPF computation, which we call the iterative approach. We use both approaches to solve the linear power flow problem (16).

4.1. Direct approach

For the direct approach, a fixed value for $|\hat{V}_n|$ and \hat{Q}_k have to be chosen. We assume $0 \leq |\hat{V}_n| \leq 1$, as the power flow computations are done in per unit normalization, and $|V_k| = 1$ for all generator buses. For example, we could take $|\hat{V}_n| = .9$ for all load nodes. One way to estimate \hat{Q}_k could be to use a power factor and the specified active power P_k of the generator buses. With the fixed values for $|\hat{V}_n|$ and \hat{Q}_k , we can solve V_2 directly from the second row of (16) as:

$$Y_{22}V_2 = -Y_{21}V_1, \tag{18}$$

$$b = -Y_{21}V_1, \tag{19}$$

$$V_2 = Y_{22}^{-1}b. \tag{20}$$

If we could initialize $|\hat{V}_n|$ and \hat{Q}_k with good values, i.e. values which are not far from the actual solutions, then the solution V_2 computed in (20) will be accurate to the actual solution V in (4). Thus, the solution of the direct approach stays within the required accuracy for some power flow problems.

4.2. Iterative approach

If these good values are hard to choose for the resistance R and reactance X of the additional branches, we can still find the solution V_2 of (16) by solving (19) iteratively. For this iterative approach, we distinguish networks without PV-buses and networks with additional PV-buses. The process of the iterative LPF method is given in Algorithm 1. For a network consisting only of PQ-buses and one swing bus, steps 3, 5, and 16–20 must be skipped. Then, this algorithm starts with an initial value for $|\hat{V}_n|$ and is updated in every iteration h . We start with a nominal initial value: $|\hat{V}_n| = 1$. In our approach,

Algorithm 1 Iterative LPF method for both PQ- and PV-buses

- 1: Set iteration counter to zero $h := 0$
- 2: Give initial $|\hat{V}_n^0|$ for all nonzero load buses n with $S > 0$ (between 0.5 and 1)
- 3: Give initial \hat{Q}_k^0 for all generator buses k
- 4: Compute initial R_{ng}^0 and X_{ng}^0 using (10)
- 5: Compute initial R_{kg}^0 and X_{kg}^0 using (12)
- 6: Compute Y including additional branches
- 7: Segment Y into Y_{11} , Y_{21} and Y_{22} , and compute b from (18)
- 8: **while** not converged **do**:
- 9: Solve (19) for V_2^h
- 10: **for** PQ-buses $n = 1, \dots, N$ **do**:
- 11: Replace iterate $|\hat{V}_n^{h+1}| := |V_2^h(S > 0)|$
- 12: Compute R_{ng}^{h+1} and X_{ng}^{h+1} using (10) with $|\hat{V}_n^{h+1}|$
- 13: Update elements of Y_{22} w.r.t R_{ng}^{h+1} and X_{ng}^{h+1}
- 14: **end for**
- 15: **for** PV-buses $k = 1, \dots, K$ **do**:
- 16: Compute complex power S^h using computed V^h
- 17: Compute ΔP as $\Delta P = P_k + \Re\{S_k^h\}$
- 18: Update iterate $\hat{Q}_k^{h+1} := \hat{Q}_k^h + \Delta P$
- 19: Compute R_{kg}^{h+1} and X_{kg}^{h+1} using (12) with \hat{Q}_k^{h+1}
- 20: Update elements of Y_{22} w.r.t R_{kg}^{h+1} and X_{kg}^{h+1}
- 21: **end for**
- 22: $h := h + 1$
- 23: **end while**

we update $|\hat{V}_n^h|$ by replacing it with $|\hat{V}_n^{h+1}| := |V_2^h(S > 0)|$, where V_2^h is computed from (19) with Y_{22} based on $|\hat{V}_n^h|$, and $(S > 0)$ indicates all nonzero load buses.

The iteration process stops when the infinity norm of $\Delta|V_n| = |\hat{V}_n^{h+1}| - |\hat{V}_n^h|$ is smaller than some tolerance, that is, when $\|\Delta|V_n|\|_\infty \leq 10^{-5}$.

In this approach, it is unnecessary to rebuild the full admittance matrix Y in every iteration. Instead, we build Y once and update only those elements of matrix Y_{22} related to nonzero loads, using new iterate $|\hat{V}_n^{h+1}|$. The following steps show how we can update matrix Y_{22} without rebuilding it again:

- 1: Let u be the vector of locations of nonzero load buses ($S > 0$) and generator buses for Y_{22} .
- 2: Compute the error $e = y_{ig}^{h+1} - y_{ig}^h$, where

$$y_{ig}^h = \frac{1}{R_{ig}^h + iX_{ig}^h}.$$

- 3: $Y_{22}(u, u) = Y_{22}(u, u) + \text{diag}(e)$, where $\text{diag}(e)$ is a diagonal matrix with e on its main diagonal.

This modification is done in steps 13 and 20 of Algorithm 1.

If the network contains generators, or PV-buses, modifications are needed. The generators could be modeled as PQ-buses, which requires a good estimate of Q . Another option is to use all the steps of Algorithm 1, to iteratively determine both $|V|$ for PQ-buses and Q for PV-buses. The process for $|V|$ is unchanged. To determine Q for the generators, we start with an initial reactive power \hat{Q}_k^0 for all generator buses k and compute R_{kg}^{h+1} and X_{kg}^{h+1} using (12) with \hat{Q}_k^{h+1} in every iteration. The most challenging part is to properly update \hat{Q}_k^{h+1} using other computed parameters, such as V_2^h . In our approach, we update \hat{Q}_k^{h+1} as $\hat{Q}_k^{h+1} := \hat{Q}_k^h + \Delta P$ using the active power mismatch ΔP that is computed as $\Delta P = P_k + \Re\{S_k^h\}$, where $\Re\{\cdot\}$ denotes the real part. The iteration process is stopped when the infinity norm of $\Delta|V_n| = |\hat{V}_n^{h+1}| - |\hat{V}_n^h|$, or the infinity norm of ΔP , is smaller than some tolerance. That is, when $\|\Delta|V_n|\|_\infty \leq 10^{-5}$ or $\|\Delta P\|_\infty \leq 10^{-5}$.

5. Numerical results

We validate our direct and iterative linear approach by comparing its accuracy and efficiency with the NPF computations on various transmission and distribution networks. We compare our iterative LPF method with DC power flow, which is the most commonly used linearized method. Lastly, we also combine the direct LPF with the NPF method, to investigate this combination as an additional use of the LPF approach, and again compare it with NPF.

Table 1
Matpower test-cases. Each test-case is either a transmission or distribution network, consisting of the given number of buses, generators, and branches.

Test-case	Buses	Generators	Branches
Transmission networks			
Tcase9	9	3	9
Tcase30	30	6	41
Tcase57	57	7	80
Tcase89	89	12	210
Tcase118	118	54	186
Distribution networks			
Dcase22	22	1	21
Dcase33 [17]	33	1	32
Dcase69 [18]	69	1	68
Dcase85	85	1	84
Dcase141	141	1	140

Table 2
The CPU time and the relative difference between NPF and direct LPF ($|\hat{V}_n| = |V_n^N|$ & $\hat{Q}_k = Q_k^N$) computations. The CPU time also includes data processing time.

Test-case	LPF	NPF	Time (NPF) Time (LPF)	$\frac{\ V^N - V^L\ _2}{\ V^N\ _2}$
	Time(s)	Time(s) & Iter		
Transmission networks				
Tcase89	0.0032	0.0233 & 4 it	7.25	8.88×10^{-11}
Tcase118	0.0029	0.0206 & 3 it	7.04	3.06×10^{-7}
Distribution networks				
Dcase85	0.0027	0.0204 & 3 it	7.61	4.65×10^{-8}
Dcase141	0.0026	0.0206 & 3 it	7.76	2.36×10^{-10}

We use the Newton power flow algorithm [16] for the NPF computations. The computations are done in Matlab, and we use five balanced transmission and five balanced distribution test-cases from Matpower, given in Table 1. Each method is tested on a set of these test-cases. The relative convergence tolerance is set to 10^{-5} for both the NPF method and the iterative LPF algorithm. We set the maximum number of iterations to 10 for NPF and to 100 for the iterative LPF computations. All numerical experiments are performed on an Intel computer i5-6500 3.2 GHz CPU with four cores and 64 GB memory.

5.1. Direct approach

In the direct approach, we have to choose the parameters $|\hat{V}_n|$ and \hat{Q}_k before the computations. As a first option, we use the actual values of $|\hat{V}_n|$ and \hat{Q}_k to solve (10), to show that our method gives the correct solution of (3). As actual values we take the solution of NPF computations.

Table 2 shows the numerical results for several test-cases. The output of the LPF computations are compared with NPF on CPU time and on the relative difference $\frac{\|V^N - V^L\|_2}{\|V^N\|_2}$, where V^N and V^L are the computed voltages of NPF and LPF computations respectively.

Table 2 shows that our LPF method indeed gives the same solution as NPF, when the solution of NPF is used to determine the resistance and reactance of the additional lines. However, $|\hat{V}_n|$ of nonzero load buses, and \hat{Q}_k of generator buses are unknown until we solve the power flow problem. Fortunately, it is possible to make reasonable estimates for $|\hat{V}_n|$ and \hat{Q}_k using information of the physical network and of the mathematical model (see Section 4.1). Furthermore, the CPU time of our direct LPF method will be the same for any value of $|\hat{V}_n|$ and \hat{Q}_k since it is a direct (non-iterative) method.

To investigate the accuracy of our method, we use various values for $|\hat{V}_n|$ and \hat{Q}_k . The results are shown in Table 3. It shows the relative difference between NPF and LPF computations when we set the same value $|\hat{V}_n|$ for all nonzero load buses n , and when we take \hat{Q}_k for all generator buses k as $\hat{Q}_k = Q_k^N - \epsilon$. Here ϵ is a small constant, for which we take $\epsilon = 0.001$. We can observe that the LPF solution is close to the NPF solution for both test-cases, even though $|\hat{V}_n|$ is chosen the same for all nonzero load buses n . For test-case Tcase89, $|\hat{V}_n| = 1$ gives more accurate results, whereas $|\hat{V}_n| = 0.9$ is the better choice for Dcase85. Moreover, the accuracy can be further improved by choosing a non-flat value for $|\hat{V}_n|$.

Fig. 2 shows the voltage profile of test-case Dcase85 for both NPF and LPF with various flat inputs for $|\hat{V}_n|$.

This shows more clearly that our LPF method can be as accurate as NPF methods, when the initial $|\hat{V}_n|$ is chosen correctly. In addition, as we have seen in Table 2, our direct LPF approach is around seven times faster than the NPF computation. Thus, this direct linear power flow approach can be a very powerful tool for electrical grid operators to

Table 3

Relative difference between NPF and direct LPF ($|\hat{V}_n| = \{0.9; 0.95; 1\}$ and $\hat{Q}_k = Q_k^N - \epsilon$).

Test-case	Relative difference $\frac{\ V^N - V^L\ _2}{\ V^N\ _2}$		
	$ \hat{V}_n = 0.9$	$ \hat{V}_n = 0.95$	$ \hat{V}_n = 1$
Transmission network			
Tcase89	9.01×10^{-2}	4.04×10^{-2}	6.58×10^{-3}
Distribution network			
Dcase85	1.36×10^{-3}	1.33×10^{-2}	2.02×10^{-2}

Table 4

The CPU time and the relative difference between NPF and iterative LPF for distribution networks.

Test-case	NPF with $V^0 = 1$		LPF with $ \hat{V}_n^0 = 1$		$\frac{\text{Time (NPF)}}{\text{Time (LPF)}}$	$\frac{\ V^N - V^L\ _2}{\ V^N\ _2}$
	Iter	Time(s)	Iter	Time(s)		
Distribution networks						
Dcase22	2	0.0201	4	0.0030	6.72	2.27×10^{-7}
Dcase33	3	0.0194	6	0.0033	5.96	4.36×10^{-7}
Dcase69	4	0.0205	6	0.0036	5.76	5.76×10^{-7}
Dcase85	3	0.0218	7	0.0040	5.52	1.70×10^{-6}
Dcase141	3	0.0237	6	0.0043	5.50	1.34×10^{-7}

Table 5

Computed active P and reactive Q powers of the reference bus.

Test-case	P_{ref}		Q_{ref}	
	NPF	LPF	NPF	LPF
Dcase22	68.0133	68.0141	66.6574	66.6577
Dcase33	391.7677	391.7659	243.5141	243.5128
Dcase69	402.7100	402.7062	279.6764	279.6739
Dcase85	288.6937	288.6898	282.0313	282.0277
Dcase141	1253.1961	1253.1933	784.0055	784.0038

control very large networks in real time. The authors of [14] apply the direct LPF approach to very large networks. They have used the MV/LV network of Alliander DNO in the Netherlands that consists of 100,000 cable segments, over 24 million buses, three million customers (load buses), several thousands of generators and around 250 substations. Their research shows the obtained speed reduction for very large networks: The linear power flow computations using a direct approach are around seven times faster than regular NPF computations. It was shown that the computation time can be further improved by applying numerical analysis techniques to the final linear system (20) for a very large power flow problem.

5.2. Iterative approach

We use Algorithm 1 for the iterative LPF computation. First, we study only distribution network cases, since those networks do not contain PV-buses. Table 4 shows the numerical results of NPF and iterative LPF computations for the CPU time and the relative difference. Both NPF and LPF algorithms start with a flat initial guess $|V|^0 = 1$.

We can see that, the LPF computation is five to six times faster than the NPF computation, even though the LPF method needs more iterations than the NPF algorithm. Additionally, the relative difference $\frac{\|V^N - V^L\|_2}{\|V^N\|_2}$ is very small for all test-cases. In the NPF computation, the stopping condition is determined by the active ΔP and reactive ΔQ mismatches which are computed by using the nonlinear power flow equations given in (4). It is obvious that the active ΔP and reactive ΔQ mismatches computed for our LPF method using V^L , will be also small since Eq. (4) depends on the complex voltage V and $\frac{\|V^N - V^L\|_2}{\|V^N\|_2}$ is very small as shown in Table 4. Table 5 shows that the computed active P and reactive Q powers of the reference bus found with the LPF method are indeed close to the ones found by NPF.

In Fig. 3, we show the scaled residual norm $\|\Delta|V_n|\|_\infty$ for various test-cases in order to present that our iterative LPF method has linear convergence.

We can conclude that the iterative LPF method has the same accuracy as NPF algorithms, for networks consisting of only PQ-buses. Moreover, it is much faster than NPF computations. Therefore, our LPF method with this iterative approach

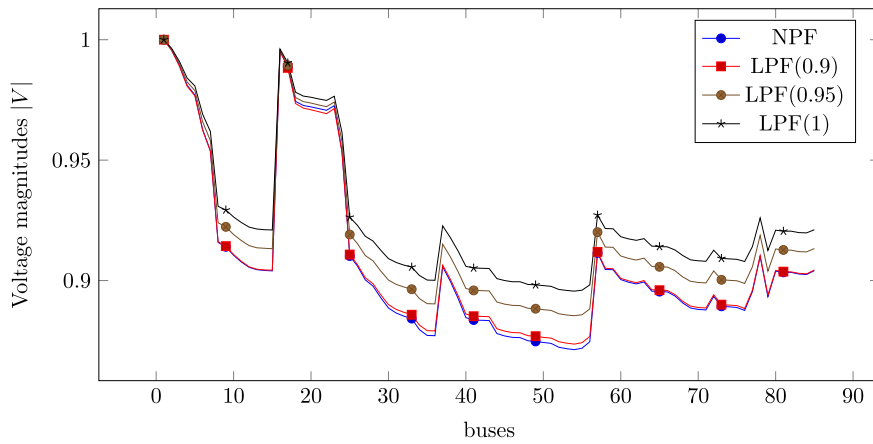

(a) Computed voltage magnitudes $|V|$

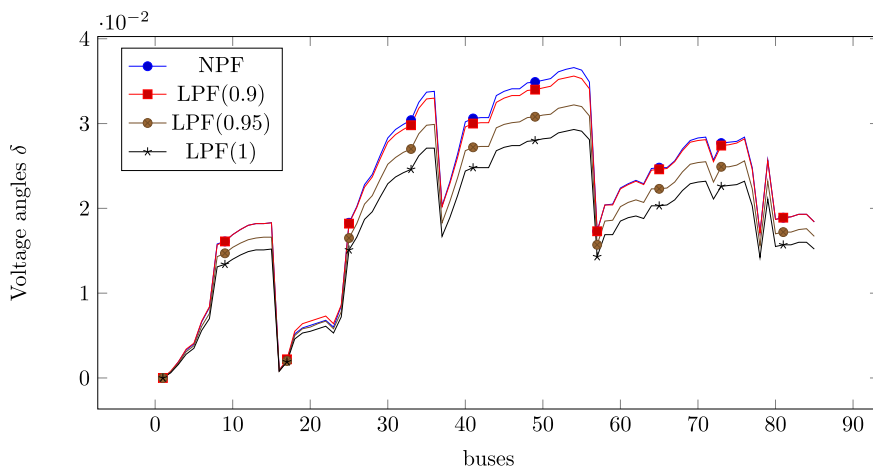

(b) Computed voltage angles $|\delta|$

Fig. 2. Voltage magnitude (a) and angle (b) profile for the test-case DCase85, using NPF and LPF with different estimates for $|\hat{V}_n|$.

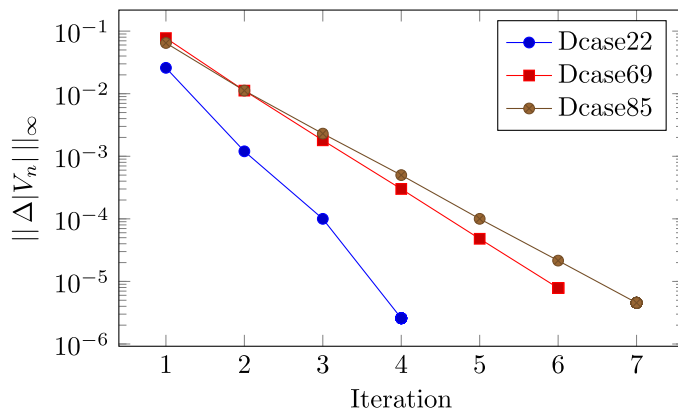

Fig. 3. Convergence of the iterative LPF method for test-cases Dcase22, Dcase69, and Dcase85.

can be used for power flow simulations on any transmission or distribution networks if generator buses can accurately be modeled as PQ-buses.

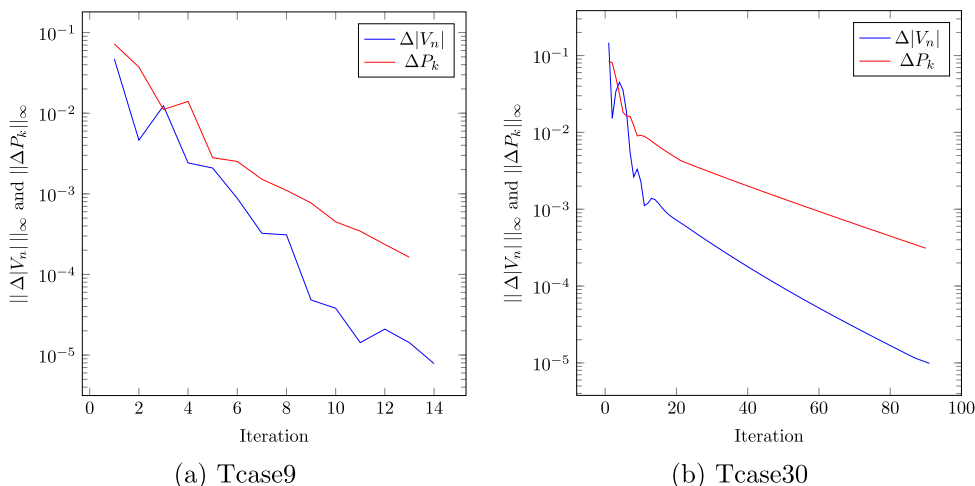

Fig. 4. Convergence of the iterative LPF method on two test-cases.

Table 6

The CPU time and the relative difference between NPF and iterative LPF for transmission networks.

Test-case	NPF($V^0 = 1$)		LPF($\hat{V}_n^0 = 1, \hat{Q}_k^0 = C$)		$\frac{\text{Time (NPF)}}{\text{Time (LPF)}}$	$\frac{\ V^N - V^L\ _2}{\ V^N\ _2}$
	Iter	Time(s)	Iter	Time(s)		
Transmission networks						
Tcase9	3	0.0226	14	0.0053	4.22	3.18×10^{-5}
Tcase30	3	0.0209	91	0.0216	0.96	1.73×10^{-4}

Table 7

The relative difference for voltage angles, with δ^N the voltage angle of NPF, δ^{DC} the voltage angle of DC, and δ^L the voltage angle of iterative LPF.

Test-case	$\frac{\ \delta^N - \delta^{DC}\ _2}{\ \delta^N\ _2}$	$\frac{\ \delta^N - \delta^L\ _2}{\ \delta^N\ _2}$
Distribution networks		
Dcase22	0.1407	1.48×10^{-5}
Dcase33	5.5710	8.08×10^{-6}
Dcase69	0.5982	1.50×10^{-5}
Dcase85	0.4246	1.56×10^{-5}
Dcase141	4.7221	2.11×10^{-6}

Second, we apply the iterative LPF method to networks with PV-buses. We use two transmission networks with a couple of generators. Both NPF and LPF algorithms start with a flat initial guess $|V|^0 = 1$. For the LPF algorithm, we start with an initial guess $\hat{Q}_k^0 = C$ for all PV-buses. We take $C = 0$, if there are no loads connected to the generator bus, or $C = Q_k^{load}$, if there are loads connected to the generator bus, with Q^{load} the total injected reactive power of the loads. Table 6 gives the numerical results of NPF and iterative LPF computations in terms of the CPU time and the relative difference. Table 6 shows that Algorithm 1 finds a solution close to the solution of the NPF computation. However, the LPF requires a large number of iterations.

In Fig. 4, we show the scaled residual norms $\|\Delta|V_n|\|_\infty$ and $\|\Delta P_k\|_\infty$ for two test-cases. We can see that Algorithm 1 has non-smooth convergence, meaning that $\hat{Q}_k^{h+1} := \hat{Q}_k^h + \Delta P$ might not be the best update for the reactive power \hat{Q}_k^{h+1} of generator buses.

5.3. Comparison to DC load flow

We compare our iterative LPF method with the DC load flow method, which solves the linear power flow problem for voltage angles δ . In Table 7, we present the relative difference for voltage angles δ computed by DC load flow, NPF, and our iterative LPF method, on various distribution networks.

We see that the relative difference in voltage angle between our iterative LPF method and NPF is much smaller than the error between DC load flow and NPF. In addition, Fig. 5 shows the voltage angle profile for the test-case DCcase22. The CPU times of both methods are comparable: 0.0050 s for DC load flow and 0.0064 s for iterative LPF for test-case DCcase22.

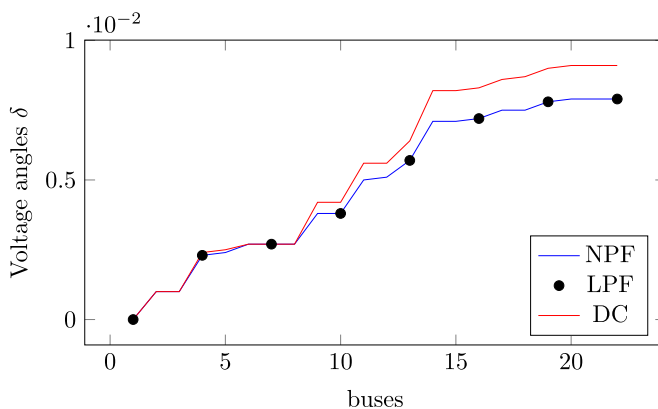

Fig. 5. Voltage angle profile for DCase22 using NPF, DC load flow, and iterative LPF.

Table 8
Number of iterations for NPF computations using different initial guesses.

Test-case	Number of iterations	
	NPF with $V^0 = 1$	NPF with $V^0 = \text{LPF}(\hat{V}_n = 0.95)$
Transmission networks		
Tcase9	3	2
Tcase30	3	2
Tcase57	3	2
Tcase89	4	2 ($ \hat{V}_n = 0.99$)
Tcase118	3	2
Distribution networks		
Dcase22	2	1
Dcase33	3	2
Dcase69	4	2
Dcase85	3	2
Dcase141	3	1

From Table 7 and Fig. 5, we can conclude that our iterative LPF method is more accurate than DC load flow for distribution power flow computations.

5.4. Direct approach combined with NPF

Usually, a flat start of $|V| = 1$ is used as an initial guess for Newton-based power flow methods. However, it is known that the Newton process has a local quadratic convergence characteristics, meaning that if the initial iterate is far from the solution, it might diverge. Since our LPF method is much faster than NPF algorithms, and provides acceptable voltage profiles using a flat estimate for $|\hat{V}_n|$, we can perform the LPF computation first, and use the result as an initial guess for NPF methods. Table 8 presents the result of NPF computations with the initial guess $V^0 = 1$ and with V^0 taken as the result of the direct LPF computation with $|\hat{V}_n| = 0.95$. The convergence of the NPF computation is improved by one to two iterations on all test-cases when the result of the LPF computation is used as an initial guess. This could be another application of our direct LPF method in power flow simulations.

6. Conclusion

In this paper, we introduce a linear formulation of the original nonlinear power flow problem. We created this linear formulation by modifying generator and load buses in the original nonlinear problem by adding artificial-additional ground buses. This results in a novel linearized method that can be solved with a direct and an iterative approach. We validate the accuracy and efficiency of the direct and iterative linear approaches by comparing their output with the conventional Newton power flow solution on various transmission and distribution networks. CPU time and relative difference are used for the comparison reasons between our LPF methods and NPF methods.

The direct LPF approach is around seven times faster than the NPF computation and can be as accurate as NPF methods if the input $|\hat{V}_n|$ and \hat{Q}_k are given within a reasonable scale. It is also concluded that if the PV-buses are modeled as PQ-buses in the network then our direct LPF approach results in very good accuracy. The main reason is that in this case, we have to approximate only $|\hat{V}_n|$ from the range between 0 and 1 because the PF computation is done in per unit

normalization. We also know that our actual solution will be in the same range as our initial guess is selected. Therefore, the difference between our initial guess and actual solution will always be small, and the solution of the direct LPF method will be even more accurate to the actual solution.

The iterative method has the same accuracy as NPF algorithms and is five to six times faster than NPF computations.

When it is difficult to find a reasonable initial guess of V for NPF, the outcome of the direct LPF method can also be used as an initial guess for NPF computations to speed up the NPF computations while maintaining high accuracy.

Overall, the direct and iterative LPF approaches are good alternatives for the computationally expensive NPF computations, making it a powerful tool for electrical grid operators that need to do real-time power system simulations of very large networks. In addition, the linear power flow Eqs. (16) can be used as equality constraints for the Optimal Power Flow (OPF) problem instead of the default nonlinear power flow equations. As a result, we can avoid the nonlinear equality constraints in the OPF formulation, reducing the computational time of OPF, since the original nonlinear power flow equations do not need to be linearized.

Further research includes improving the iterative LPF method for networks with PV-buses by investigating different ways to update the unknown reactive power of the PV-buses.

Acknowledgment

This research received funding from the Dutch Research Council (NWO) [project number: 647.002.007].

References

- [1] W.D. Stevenson, *Elements of Power System Analysis*, McGraw-Hill, 1975.
- [2] W.F. Tinney, C.E. Hart, Power flow solution by Newton's method, *IEEE Trans. Power Appar. Syst.* (11) (1967) 1449–1460.
- [3] B. Stott, O. Alsac, Fast decoupled load flow, *IEEE Trans. Power Appar. Syst.* (3) (1974) 859–869.
- [4] R.M. van Amerongen, A general-purpose version of the fast decoupled load flow, *IEEE Trans. Power Syst.* 4 (2) (1989) 760–770.
- [5] P. Schavemaker, L. Van der Sluis, *Electrical Power Systems Essentials*, John Wiley & Sons LTD, West Sussex, 2008.
- [6] J.R. Martí, H. Ahmadi, L. Bashualdo, Linear power-flow formulation based on a voltage-dependent load model, *IEEE Trans. Power Deliv.* 28 (3) (2013) 1682–1690.
- [7] O.D. Montoya, L. Grisales-Noreña, D. González-Montoya, C. Ramos-Paja, A. Garces, Linear power flow formulation for low-voltage DC power grids, *Electr. Power Syst. Res.* 163 (2018) 375–381.
- [8] O. Montoya, W. Gil-González, L. Grisales-Noreña, Linear-based Newton-Raphson approximation for power flow solution in DC power grids, in: 2018 IEEE 9th Power, Instrumentation and Measurement Meeting, EPIM, IEEE, 2018, pp. 1–6.
- [9] K. Liu, C. Wang, W. Wang, Y. Chen, H. Wu, Linear power flow calculation of distribution networks with distributed generation, *IEEE Access* 7 (2019) 44686–44695.
- [10] S. Bolognani, S. Zampieri, On the existence and linear approximation of the power flow solution in power distribution networks, *IEEE Trans. Power Syst.* 31 (1) (2015) 163–172.
- [11] A. Garces, A linear three-phase load flow for power distribution systems, *IEEE Trans. Power Syst.* 31 (1) (2015) 827–828.
- [12] H. Ahmadi, J.R. Martí, A. von Meier, A linear power flow formulation for three-phase distribution systems, *IEEE Trans. Power Syst.* 31 (6) (2016) 5012–5021.
- [13] Y. Wang, N. Zhang, H. Li, J. Yang, C. Kang, Linear three-phase power flow for unbalanced active distribution networks with PV nodes, *CSEE J. Power Energy Syst.* 3 (3) (2017) 321–324.
- [14] B. Sereeter, W. van Westering, C. Vuik, C. Witteveen, Linear power flow method improved with numerical analysis techniques applied to a very large network, *Energies* 12 (21) (2019) 4078.
- [15] H.E. Brown, G.K. Carter, H.H. Happ, C.E. Person, Z-matrix algorithms in load-flow programs, *IEEE Trans. Power Appar. Syst.* (3) (1968) 807–814.
- [16] B. Sereeter, K. Vuik, C. Witteveen, Newton power flow methods for unbalanced three-phase distribution networks, *Energies* 10 (10) (2017) 1658.
- [17] M.E. Baran, F.F. Wu, Network reconfiguration in distribution systems for loss reduction and load balancing, *IEEE Trans. Power Deliv.* 4 (2) (1989) 1401–1407.
- [18] M.E. Baran, F.F. Wu, Optimal capacitor placement on radial distribution systems, *IEEE Trans. Power Deliv.* 4 (1) (1989) 725–734.